

Product information

Periphery module

PM DIO8-Z



(valid from 06/2012 / configuration -00 and 01 with OS 2.0.32)

Description

compact peripheral module (configurable) with:

- **6 digital inputs 24V**
- **2 digital back readable outputs 24V/2A** (configuration code 00)
- inputs with alarm-function
- green diagnostic LED for each in-/ output
- insertion stripe with description field for every signal
- cage-clamp connector with self-lock and 2 lift arms

for 6 alarm inputs 24V (configuration -00 / DIO24)

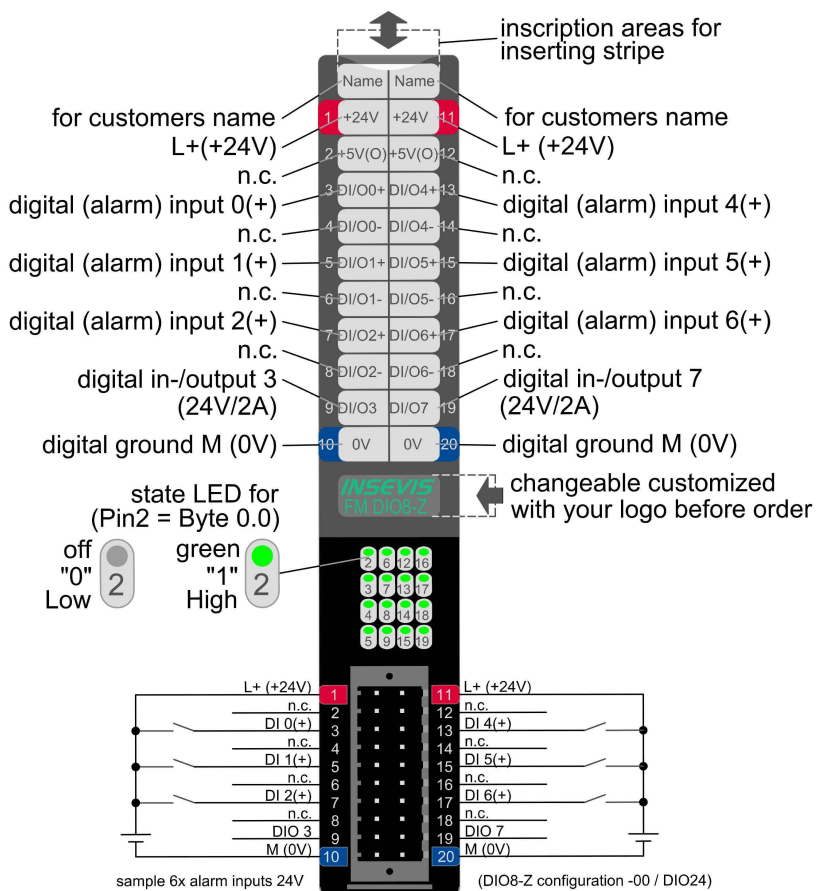
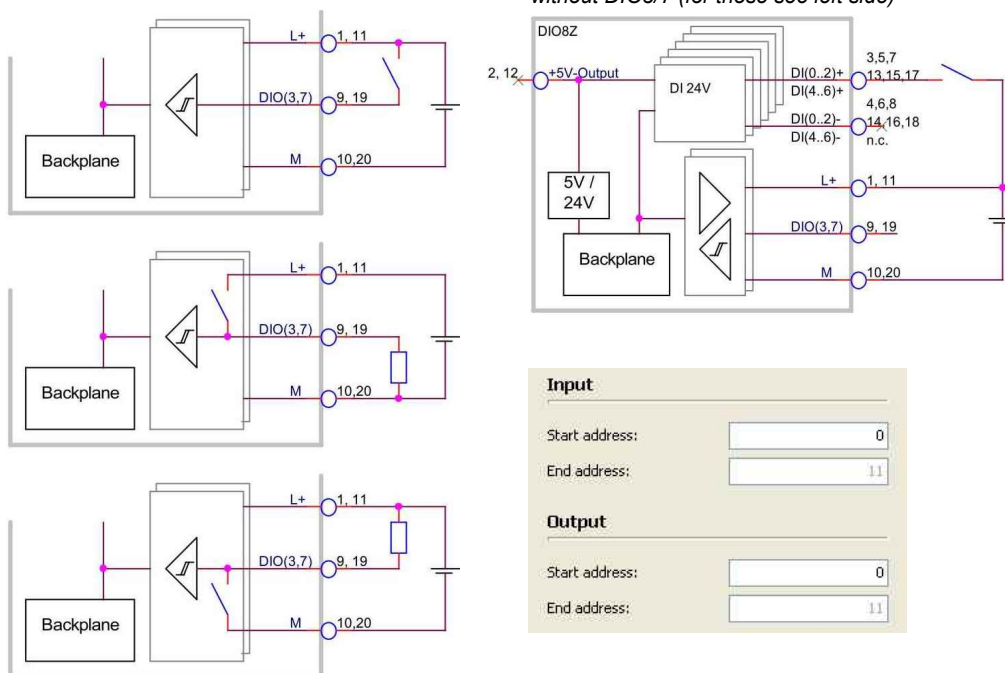

Figure above: description and wiring of all connections of peripheral module DIO8-Z-00 (DIO24)

below: block diagram of DIO8-Z-00 (DIO24) without DIO3/7 (for those see left side)



above: block diagram of DIO3 and DIO7 as input (top), as output (L+ switching, middle) and as output (M-switching, down)

above: configuration block of start-/end- addresses of DIO8-Z-in-/outputs (in byte) in the ConfigStage

Description

compact peripheral module (configurable) with:

6 digital back readable outputs 5V
2 digital back readable outputs 24V/2A
 (configuration code 01)

- inputs with alarm-function
- green diagnostic LED for each in-/ output
- insertion stripe with description field for every signal
- cage-clamp connector with self-lock and 2 lift arms

for 6 alarm inputs 5V (configuration -01 / DIO5)

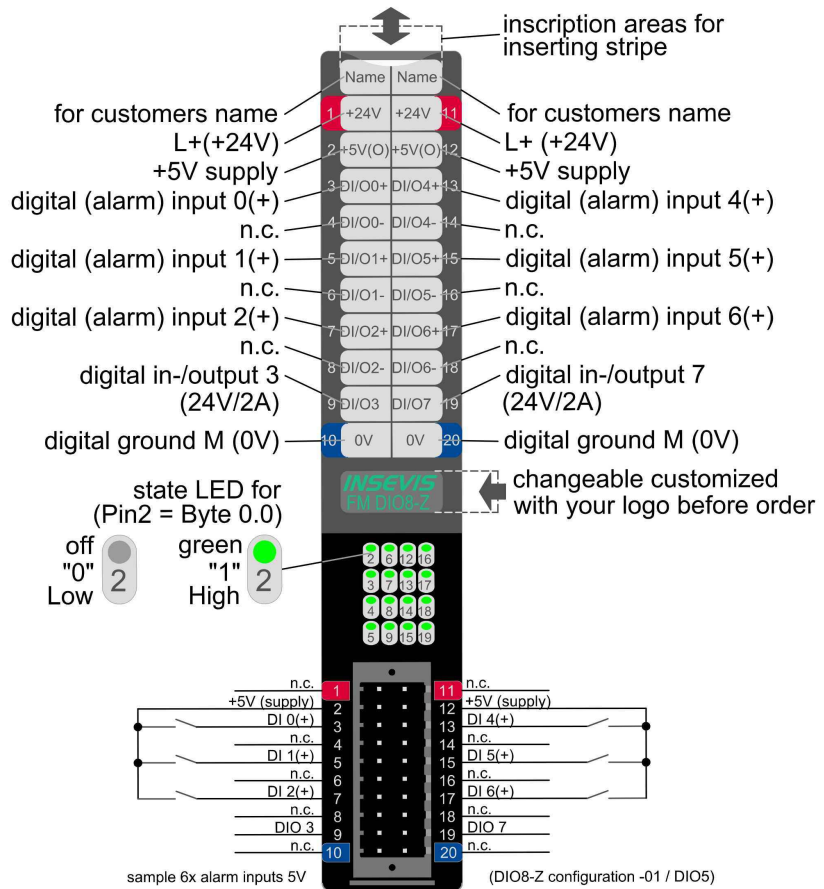
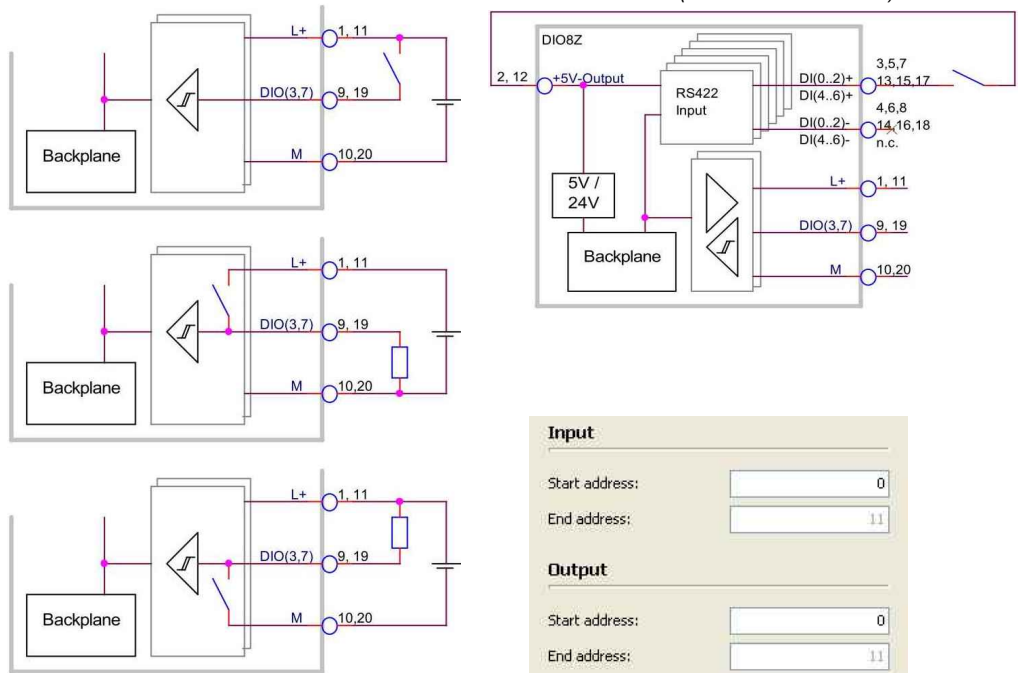

Figure above: description and wiring of all connections of peripheral module DIO8-Z-01 (DIO5)

below: block diagram of DIO8-Z-01 (DIO5) without DIO3/7 (for those see left side)



above: block diagram of DIO3 and DIO7 as input (top), as output (L+ switching, middle) and as output (M-switching, down)

above: configuration block of start-/end- addresses of DIO8-Z-in-/outputs (in byte) in the ConfigStage

Description

- compact peripheral module (configurable) with:
- 2 counter for encoder-24V with reference track
 - 2 digital back readable outputs 24V/2A (configuration code 02)
 - Metering of frequency and period time
 - Counting forward / backward with 32 Bit
 - Compare register
 - green diagnostic LED for each in-/ output
 - insertion stripe with description field for every signal
 - cage-clamp connector with self-lock and 2 lift arms

for 2 encoder 24V (configuration -02 / INK24)

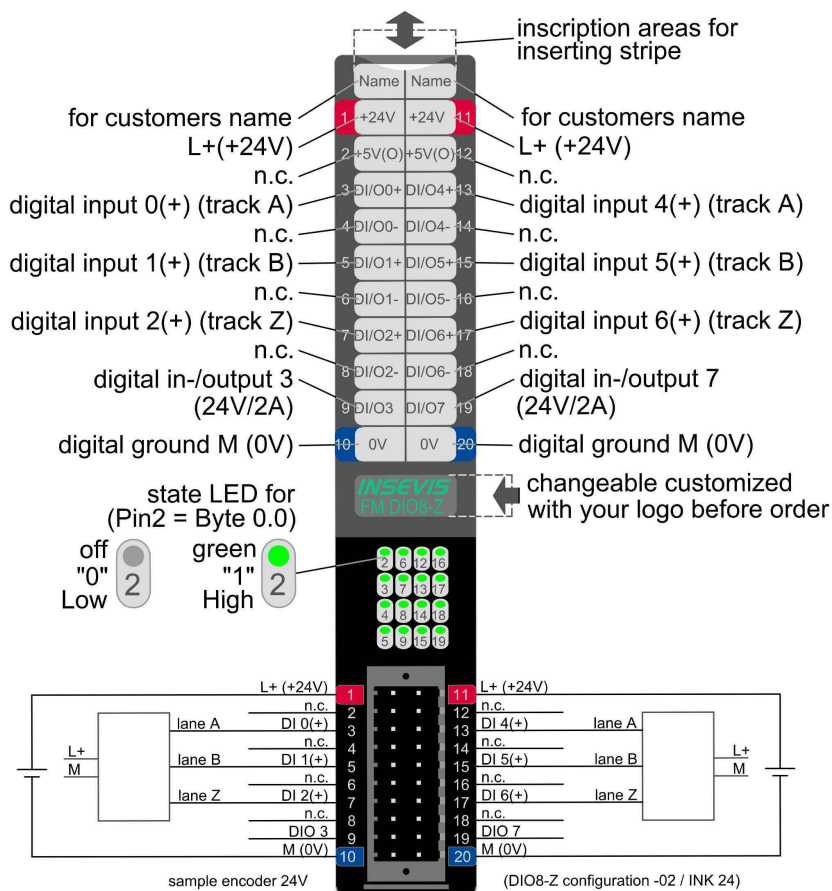
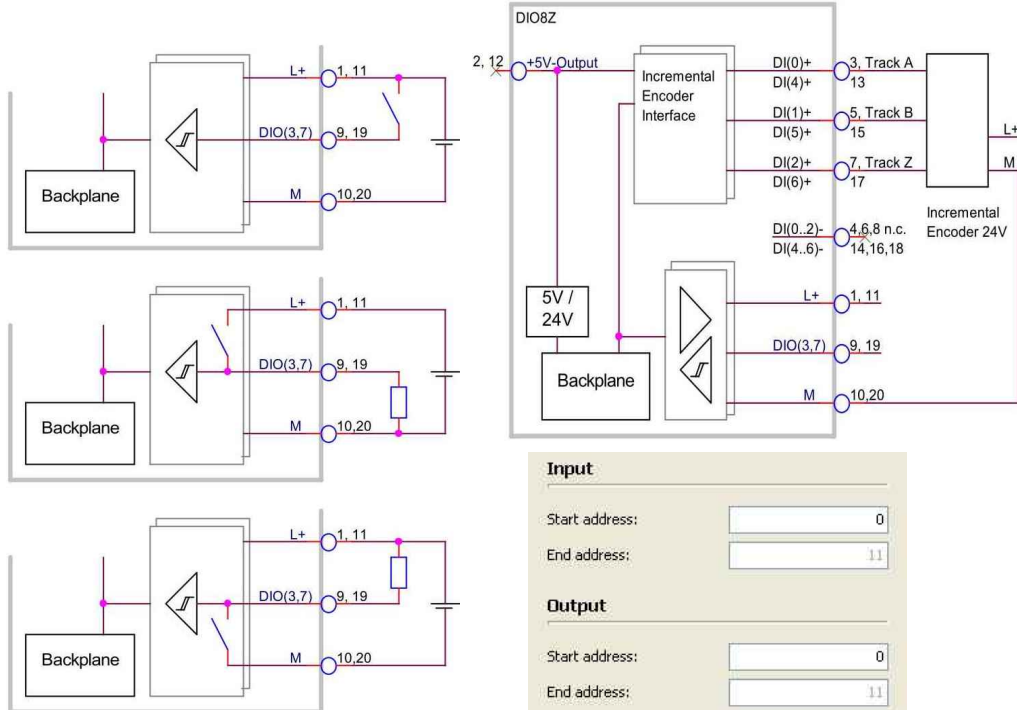

Figure above: description and wiring of all connections of peripheral module DIO8-Z-02 (INK24)

below: block diagram of DIO8-Z-02 (INK24) without DIO3/7 (for those see left side)



above: block diagram of DIO3 and DIO7 as input (top), as output (L+ switching, middle) and as output (M-switching, down)

above: configuration block of start-/end- addresses of DIO8-Z-in-/outputs (in byte) in the ConfigStage

Description

compact peripheral module (configurable) with:

- 2 counter for encoder-5V with reference track
- 2 digital back readable outputs 24V/2A (configuration code 03)

- Metering of frequency and period time

- Counting forward / backward with 32 Bit

- Compare register

- green diagnostic LED for each in-/ output

- insertion stripe with description field for every signal

- cage-clamp connector with self-lock and 2 lift arms

for 2 encoder 5V (configuration -03 / INK5)

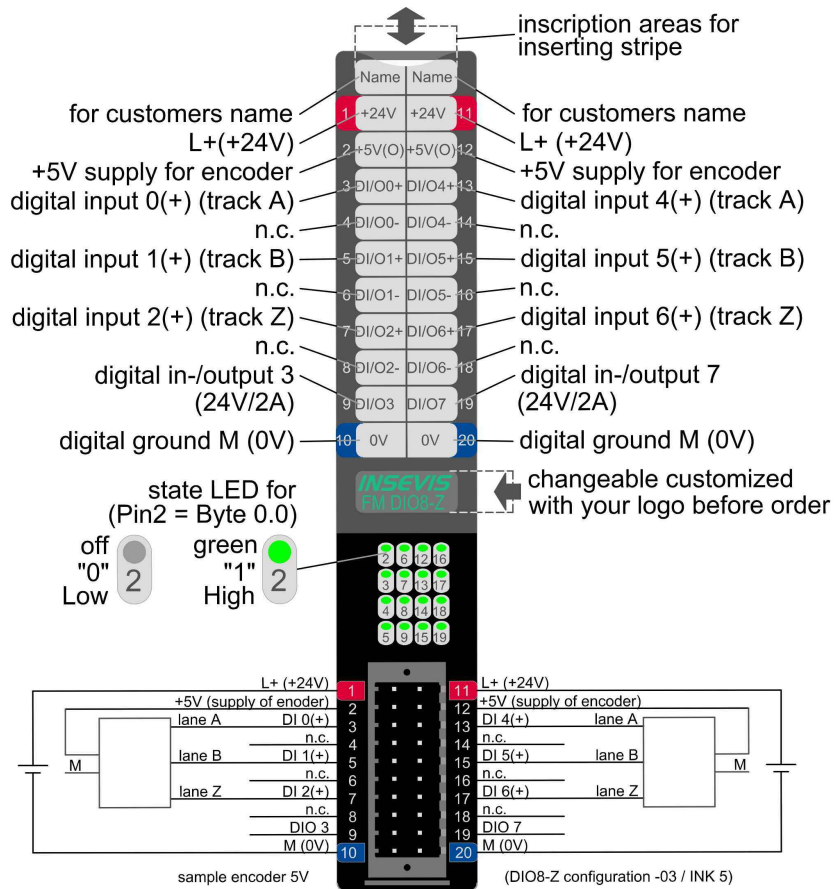
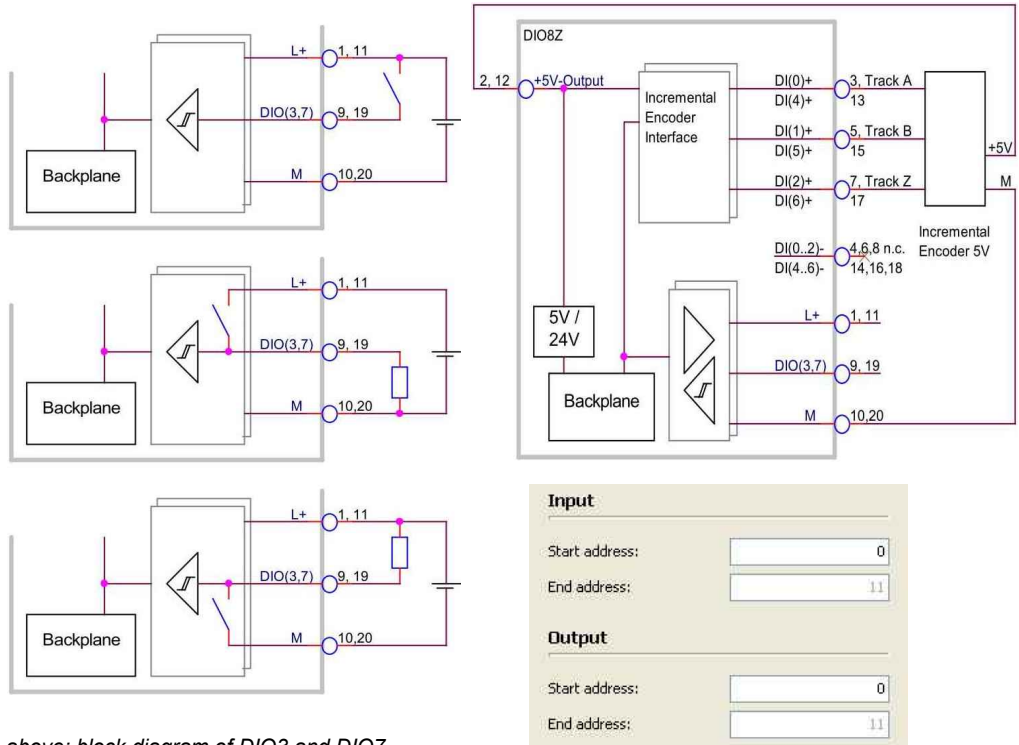

Figure above: description and wiring of all connections of peripheral module DIO8-Z-03 (INK5)

below: block diagram of DIO8-Z-03 (INK5) without DIO3/7 (for those see left side)



above: block diagram of DIO3 and DIO7 as input (top), as output (L+ switching, middle) and as output (M-switching, down)

above: configuration block of start-/end- addresses of DIO8-Z-in-/outputs (in byte) in the ConfigStage

Description

compact periphery module (configurable) with:

- 2 counter for encoder RS422 with reference track
- 2 digital back readable outputs 24V/2A (configuration code 04)
- Metering of frequency and period time
- Counting forward / backward with 32 Bit
- Compare register
- green diagnostic LED for each in-/ output
- insertion stripe with description field for every signal
- cage-clamp connector with self-lock and 2 lift arms

for 2 encoder RS422 (configuration -04 / INK RS422)

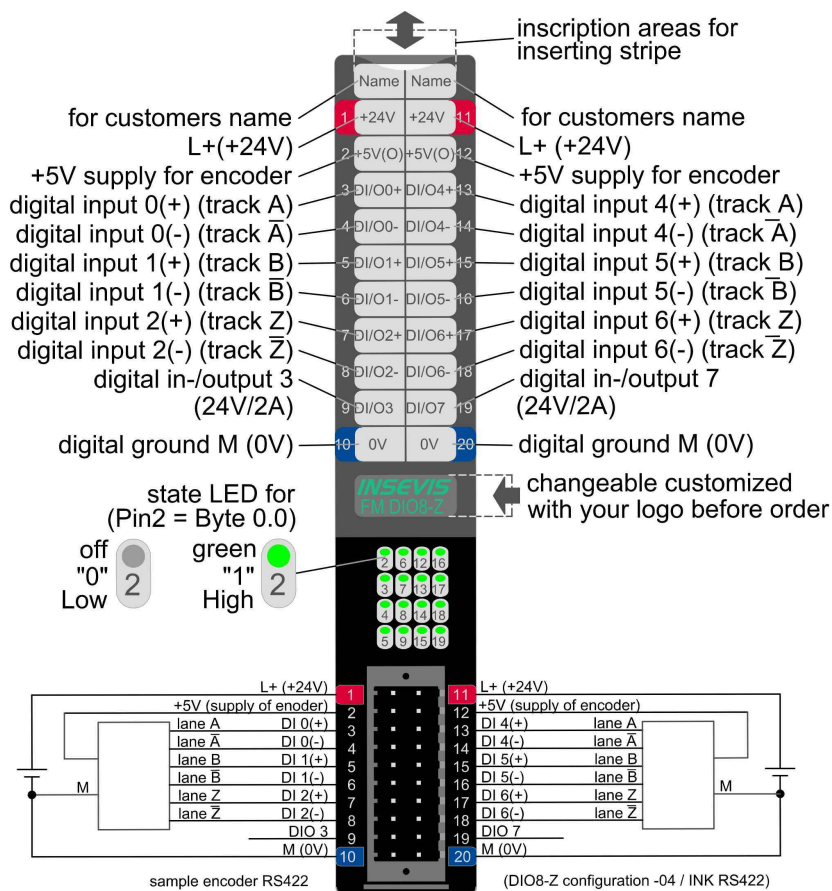
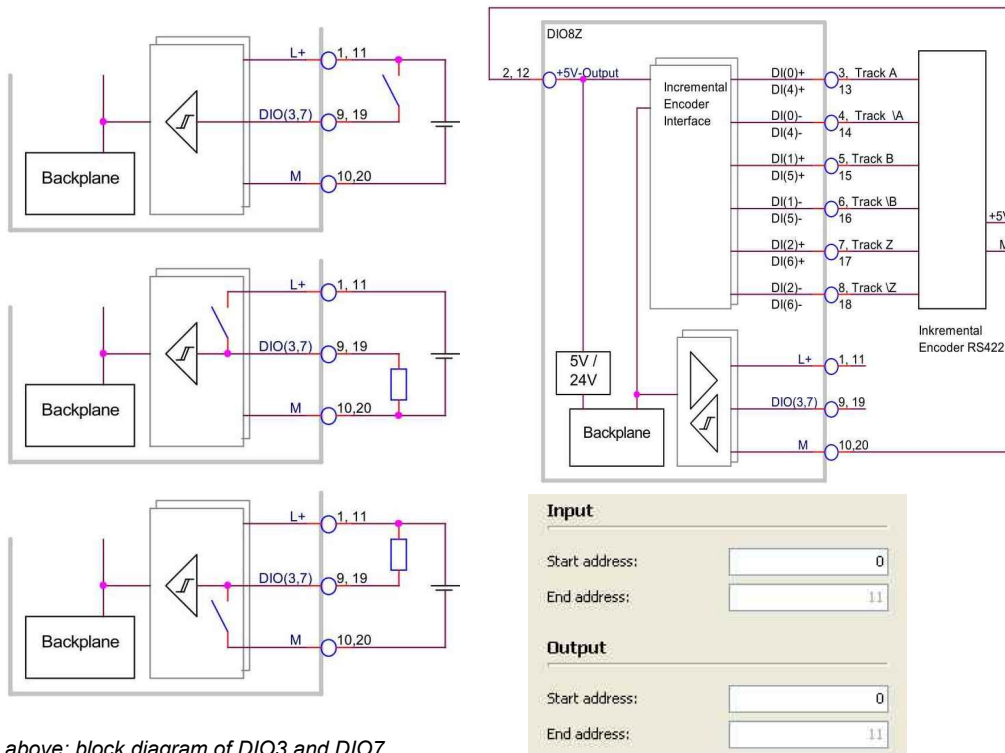

Figure above: description and wiring of all connections of periphery module DIO8-Z-04 (INK RS422)

below: block diagram of DIO8-Z-04 (INKRS422) without DIO3/7 (for those see left side)



above: block diagram of DIO3 and DIO7 as input (top), as output (L+ switching, middle) and as output (M-switching, down)

above: configuration block of start-/end- addresses of DIO8-Z-in-/outputs (in byte) in the ConfigStage

Description

compact peripheral module (configurable) with:

- 2 SSI encoder-interfaces RS422
- 2 digital back readable outputs RS422
- 2 digital back readable outputs 24V/2A (configuration code 05)

- Metering of frequency and period time

- Counting forward / backward with 32 Bit

- Compare register

- green diagnostic LED for each in-/ output

- insertion stripe with description field for every signal

- cage-clamp connector with self-lock and 2 lift arms

for 2 encoder (configuration -05 / INK SSI)

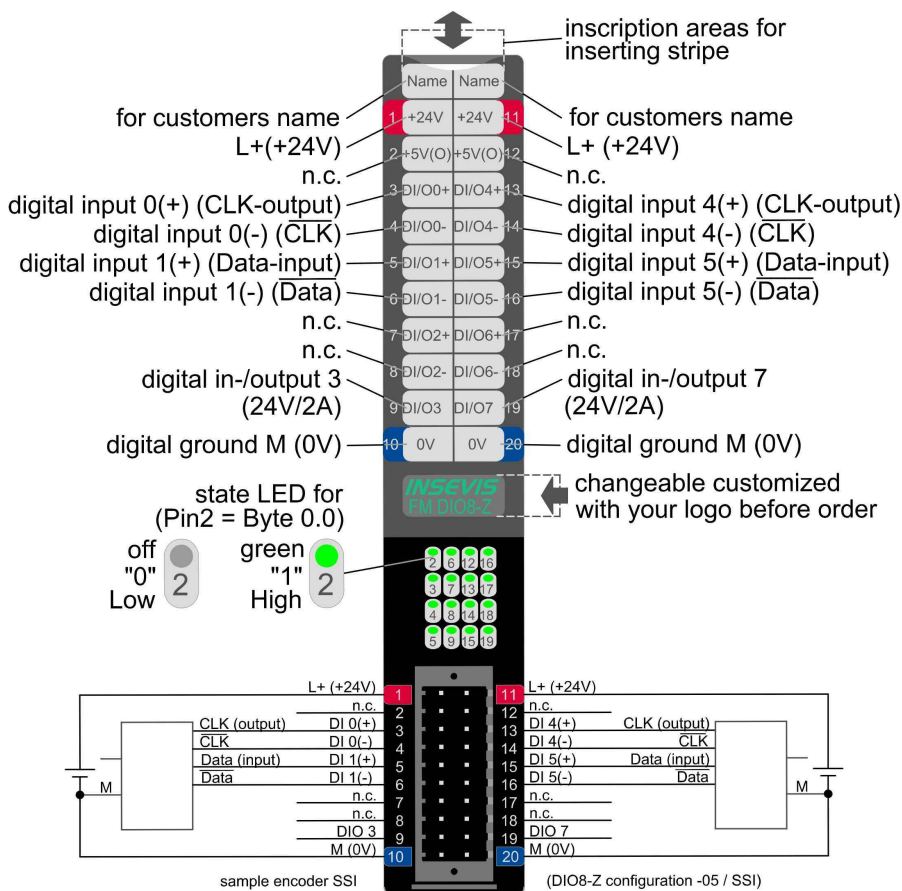
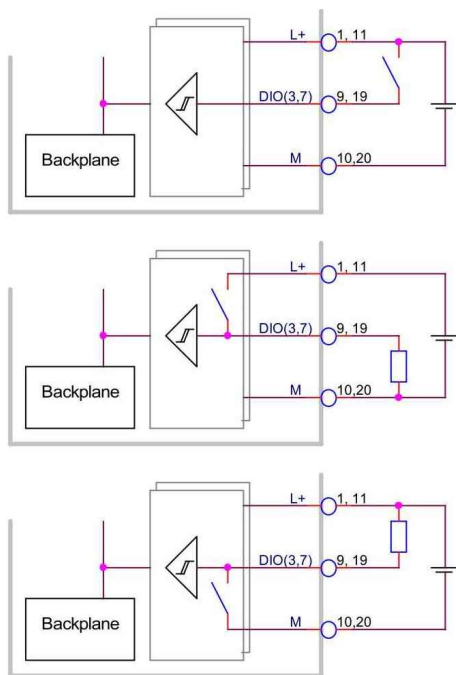
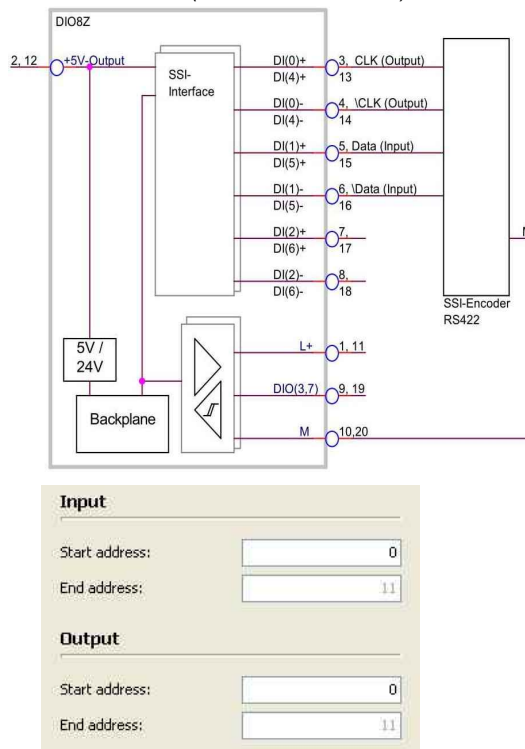

Figure above: description and wiring of all connections of peripheral module DIO8-Z-05 (INK SSI)

below: block diagram of DIO8-Z-05 (INK SSI) without DIO3/7 (for those see left side)



above: block diagram of DIO3 and DIO7 as input (top), as output (L+ switching, middle) and as output (M-switching, down)



above: configuration block of start-/end- addresses of DIO8-Z-in-/outputs (in byte) in the ConfigStage

| Technical data | |
|----------------------------------|--|
| Dimensions W x H x D (mm) | 20 x 108 x 70 mm |
| Weight | ca. 150 g |
| Operating temperature range | -20°C ... +60°C (without condensation) |
| Storage temperature range | -30°C ... +80°C |
| Connection technology | unlockable connector with self-lock and 2 lift-arms (cage clamp technology) for cross section up to max. 1mm ² |
| Load voltage L+ | 10 V ... 30 V DC |
| Current consumption | 20 mA (max.) without load |
| Power dissipation | interal limited |
| Wire length unshielded (max.) | 30m |
| shielded (max.) | 100m |

| DI/O0 ... DI/O2, DI/O4 ... DI/O6 | 24V | 5V | (RS422 without terminating resistor) | RS422 | (with terminating resistor) |
|--|---|---|---|--|--------------------------------|
| Digital inputs Diagnostic LEDs | 8 (max.), all with alert-function (interrupt) 8, green | | | | |
| Configuration codes | PM-DIO8Z-00-02 PM-DIO8Z-02-02 | PM-DIO8Z-01-02 PM-DIO8Z-03-02 | | PM-DIO8Z-04-02 PM-DIO8Z-05-02 | |
| Input voltage for signal 0 for signal 1 | 0V ... +5V +7,5V ... +30V | 0 .. +3V +4 .. +5V | | | |
| positive switching | DI/O0(+)..7(+): signal DI/O0(-)..2(-), 4(-) .. 6(-): open | DI/O0(+)..2(+), 4(+).. 6(+): signal DI/O0(-)..2(-), 4(-) .. 6(-): open | | | |
| Input voltage for signal 0 for signal 1 | +2V ... +30V 0V ... +1V | +2..+5V 0..+1V | | | |
| negative switching "open collector" | DI/O0(+).. 2(+), 4(+).. 6(+): open DI/O0(-).. 2(-), 4(-) .. 6(-): signal | DI/O0(+).. 2(+), 4(+).. 6(+): open DI/O0(-).. 2(-), 4(-) .. 6(-): signal | | | |
| Inputs (differential) Outputs | - - | | | differential reg. RS422 differential reg. RS422 | |
| Input resistance | - | 1,5 kOhm | | | 150 Ohm |
| Input current for signal 1 | max.1mA (subject to change) | | | | |
| Broken wire detection Error diagnostic Potential seperation to PLC | no no no | | | | |
| Input delay Output delay | 2 µs (typ.) 2 µs (typ.) | | | | |
| Max. counting frequency | 125kHz (subject to change) | | | | |

| DI/O3, DI/O7 | | | | | |
|--|---|--|--|------------------------------|--|
| Digital outputs Diagnostic LEDs | 2 with L+ 2, green | | | | |
| Output signal level for signal 0 for signal 1 | 1,0 V bei 500Ω (max.) L+ - 1,0V bei 0,5A Last (min.) | Input signal level for signal 0 for signal 1 | | 0V ... +5V +7,5V ... +30V | |
| Output current for signal 0 for signal 1 | 0,5mA (max.) 2 A (max. bis 60°C, subject to change) | | | | |
| Output delay | 30 µs (typ., without load) | Input delay | | 50 µs (typ.) | |
| Max. switching frequency with ohmic load | 100 Hz | | | | |
| Broken wire detection Error diagnostic Potential seperation to PLC | no no no | | | | |

Documentation and samples



web: www.insevis.com
 register: Products / Periphery
 download: TI-PM xxxx.pdf
 register: Documentation
 download: Manual Periphery.pdf



web: www.insevis.com
 register: Service
 Periphery
 It will be provided documented samples for all functions to be downloaded free of charge.

Ordering data module

| Identification | Order-no. | Packaging unit |
|---|----------------|----------------|
| Periphery module DIO8-Z DIO24 - with 6dI (24V) + 2dO (24V/2A) | PM-DIO8Z-00-02 | PU: 1 piece |
| Periphery module DIO8-Z DIO5 - with 6dI (5V) + 2dO (24V/2A) | PM-DIO8Z-01-02 | PU: 1 piece |
| Periphery module DIO8-Z INK24 - with 6cI (24V) +2dO (24V/2A) | PM-DIO8Z-02-02 | PU: 1 piece |
| Periphery module DIO8-Z INK5 - with 6cI (5V) + 2dO (24V/2A) | PM-DIO8Z-03-02 | PU: 1 piece |
| Periphery module DIO8-Z INK422 - with 6cI (RS422) + 2dO (24V/2A) | PM-DIO8Z-04-02 | PU: 1 piece |
| Periphery module DIO8-Z SSI - with 6cI (RS422) + 2dO (24V/2A) | PM-DIO8Z-05-02 | PU: 1 piece |

Ordering data accessoires

| Identification | Order-no. | Packaging unit |
|--|--------------|----------------|
| Connector 2x10pin | E-CON20-00 | PU: 1 piece |
| Inserting stripe for description fields, 2x11 fields * | E-LABES22-00 | PU: 20 pieces |
| Inserting stripe V for logo and identification for rear side | E-LABV-00 | PU: 100 pieces |

* (1x already part of first deliveries scope)

Copyright

This and all other documentation and software, supplied or hosted on INSEVIS web sites to download are copyrighted. Any duplicating of these data in any way without express approval by INSEVIS GmbH is not permitted.

All property and copy rights of these documentation and software and every copy of it are reserved to INSEVIS GmbH.

Trade Marks

INSEVIS refers that all trade marks of particular companies used in own documentation as e.g.

- STEP®, SIMATIC® and other as reserved trade mark of SIEMENS AG.

- CANopen® and other as reserved trade mark of CAN in Automation eG

and more reserved trade marks are property of the particular owners and are subjected to common protection of trade marks.

Disclaimer

All technical details in this documentation were created by INSEVIS with highest diligence. Anyhow mistakes could not be excluded, so no responsibility is taken by INSEVIS for the complete correctness of this information. This documentation will reviewed regularly and necessary corrections will be done in next version.

With publication of this catalog all other versions are no longer valid.